



Content



Page 3-4	Phase-Line 120 DW	Invisible integrable mid-high loudspeaker with drywall gypsum plaster front
Page 5-6	Phase-Line 120 DW CE	Invisible horizontally integrable mid-high loudspeaker with drywall gypsum plaster front
Page 7-8	Phase-Line 240 DW CE	Invisible horizontally integrable mid-high loudspeaker with drywall gypsum plaster front
Page 9-10	Phase-Line 240 DW LS	Invisible integrable mid-high line source loudspeaker with drywall gypsum plaster front
Page 11-12	Phase-Line 400 DW LS	Invisible integrable mid-high line source loudspeaker with drywall gypsum plaster front
Page 13-14	Phase-Line 700 DW LS	Invisible integrable mid-high line source loudspeaker with drywall gypsum plaster front
Page 15-16	Phase-Line 120 CM	Invisible integrable mid-high loudspeaker for wooden boards and laminates
Page 17-18	Phase-Line 120 CM LB	Invisible horizontally integrable mid-high loudspeaker for wooden boards and laminates
Page 19-20	Phase-Line 240 CM LB	Invisible horizontally integrable mid-high loudspeaker for wooden boards and laminates
Page 21-22	Phase-Line 240 CM LS	Invisible integrable mid-high line source loudspeaker for wooden boards and laminates
Page 23-24	Phase-Line 400 CM LS	Invisible integrable mid-high line source loudspeaker for wooden boards and laminates
Page 25-26	Phase-Line 700 CM LS	Invisible integrable mid-high line source loudspeaker for wooden boards and laminates
Page 27-28	Phase-Line Concert 400 CS	Mid-high line source loudspeaker
Page 29-30	Phase-Line Concert 700 CS	Mid-high line source loudspeaker
Page 31-32	Sub 12 DW	Invisible integrable subwoofer with drywall gypsum plaster front
Page 33-34	Sub 12 FF	Flat frontfire subwoofer
Page 35-36	Sub 12 SF	Slotfire subwoofer for integration in hollow spaces
Page 37-38	Sub 12-2 SF	Slotfire subwoofer for integration in hollow spaces
Page 39-40	Sub 12-2 Boxer DF	Downfire subwoofer, impulse compensated
Page 41-42	Sub 12-2 Boxer DF Slot	Downfire subwoofer, impulse compensated
Page 43-44	Sub 302 DF	Downfire subwoofer, impulse compensated
Page 45-46	Sub15 FF	Frontfire subwoofer
Page 47-48	Sub15-2 FF	Frontfire subwoofer
Page 49-50	Sub 15-2 Boxer DF	Downfire subwoofer, impulse compensated
Page 51-52	Amp 19	2 - 8 channel 19" DSP amplifier

Phase-Line 120 DW

Invisible Mid-High Loudspeaker for Drywall and Solid Construction



When installing in vertical surfaces, install upright

Description / Technical data

Flat panel loudspeaker on the principle of the bending wave transducer with a flat panel membrane, which is brought to vibration by electrical exciters mounted to the back and due to a special construction, the principle-related diffuse radiation characteristic is converted into a direct sound radiation characteristic.

The loudspeaker comprises a conventional gypsum plaster board with a factory-integrated flat panel loudspeaker.

The 12.5 mm plaster board is raised by ambossing the area of the membrane. This enables flush filling with joint tape to the surrounding planking without having to plaster the membrane. This guarantees absolute sound neutrality after installation.

The surface can be coated with all conventional materials, such as, for example, paint, wallpapers, etc.



Dimensions:	500 mm x 625 mm x 66 mm
Material:	Gypsum plaster board
Frequency range:	120 Hz – 20000 Hz
Equalization:	LoftSonic DSP amplifier
Dispersion angle:	180° x 180°
Power handling*:	120 W / 8 Ω
Sensitivity:	88 dB (1 W / 1m)
Max. SPL:	106 dB (1 m)

Manufacturer:	Loftsonic GmbH & Co. KG
Model:	LoftSonic Phase-Line 120 DW

* Peak with HP 24 dB/oct 220 Hz

Phase-Line 120 DW

Invisible Mid-High Loudspeaker for Drywall and Solid Construction



When installing in vertical surfaces, install upright

Dimensions drawing

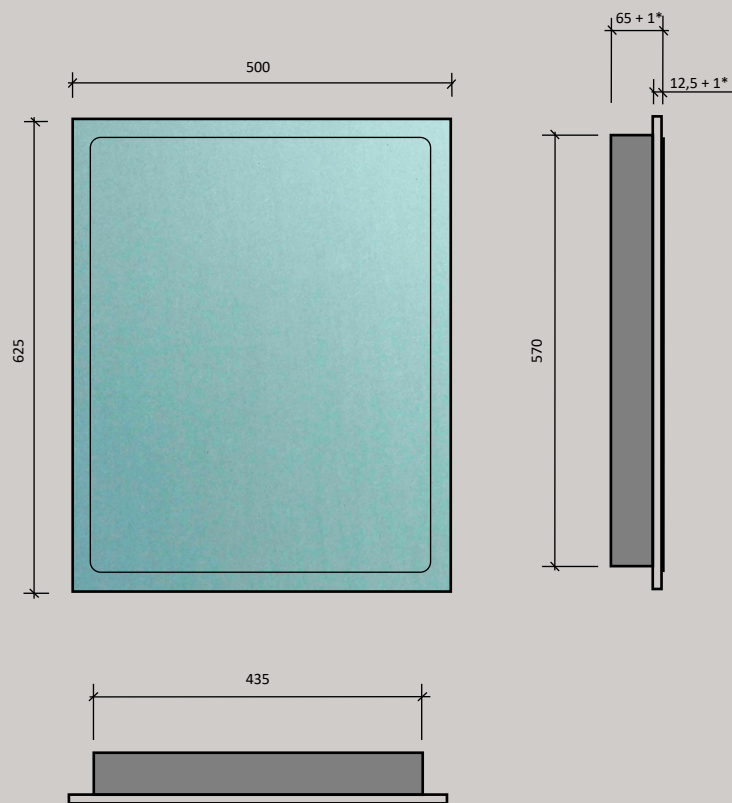

***Raised membrane**

Dimensions in mm

Phase-Line 120 DW CE

Invisible Mid-High Loudspeaker for horizontal installation in Drywall and Solid Construction

When installing in vertical surfaces, install crosswise



Description / Technical data

Flat panel loudspeaker on the principle of the bending wave transducer with a flat panel membrane, which is brought to vibration by electrical exciters mounted to the back and due to a special construction, the principle-related diffuse radiation characteristic is converted into a direct sound radiation characteristic.

The loudspeaker comprises a conventional gypsum plaster board with a factory-integrated flat panel loudspeaker.

The 12.5 mm plaster board is raised by ambossing the area of the membrane. This enables flush filling with joint tape to the surrounding planking without having to plaster the membrane. This guarantees absolute sound neutrality after installation.

The surface can be coated with all conventional materials, such as, for example, paint, wallpapers, etc.

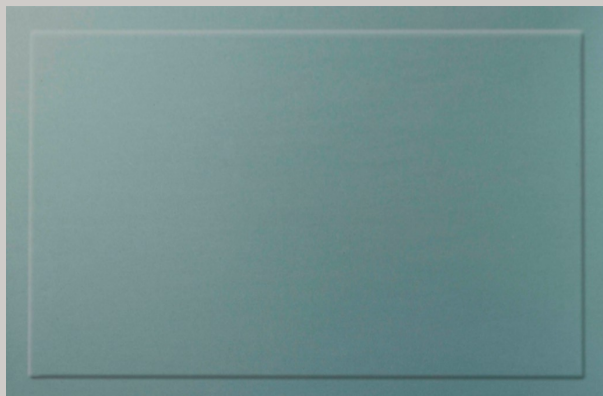

Dimensions:	625 mm x 410 mm x 66 mm
Material:	Gypsum plaster board
Frequency range:	120 Hz – 20000 Hz
Equalization:	LoftSonic DSP amplifier
Dispersion angle:	180° x 180°
Power handling*:	120 W / 8 Ω
Sensitivity:	88 dB (1 W / 1m)
Max. SPL:	106 dB (1 m)
Manufacturer:	Loftsonic GmbH & Co. KG
Model:	LoftSonic Phase-Line 120 DW CE

* Peak with HP 24 dB/oct 220 Hz

Phase-Line 120 DW CE

Invisible Mid-High Loudspeaker for horizontal installation in Drywall and Solid Construction



When installing in vertical surfaces, install crosswise

Dimensions drawing

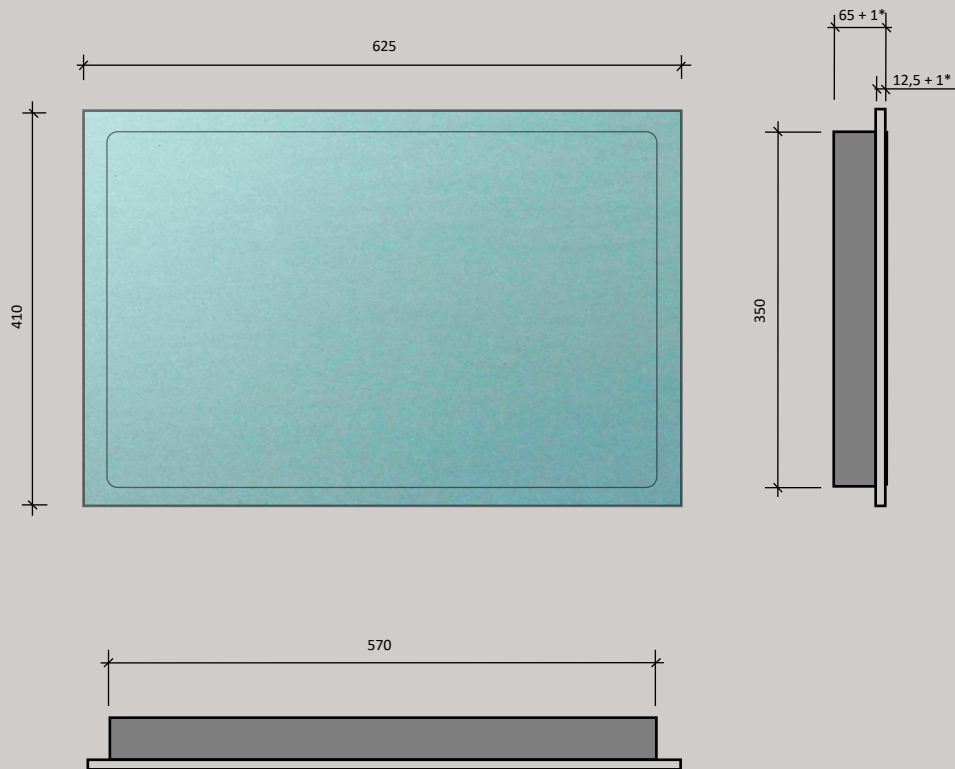

*Raised membrane

Dimensions in mm

Phase-Line 240 DW CE

Invisible Mid-High Loudspeaker for horizontal installation in Drywall and Solid Construction

When installing in vertical surfaces, install crosswise



Description / Technical data

Flat panel loudspeaker on the principle of the bending wave transducer with a flat panel membrane, which is brought to vibration by electrical exciters mounted to the back and due to a special construction, the principle-related diffuse radiation characteristic is converted into a direct sound radiation characteristic.

The loudspeaker comprises a conventional gypsum plaster board with a factory-integrated flat panel loudspeaker.

The 12.5 mm plaster board is raised by ambossing the area of the membrane. This enables flush filling with joint tape to the surrounding planking without having to plaster the membrane. This guarantees absolute sound neutrality after installation.

The surface can be coated with all conventional materials, such as, for example, paint, wallpapers, etc.

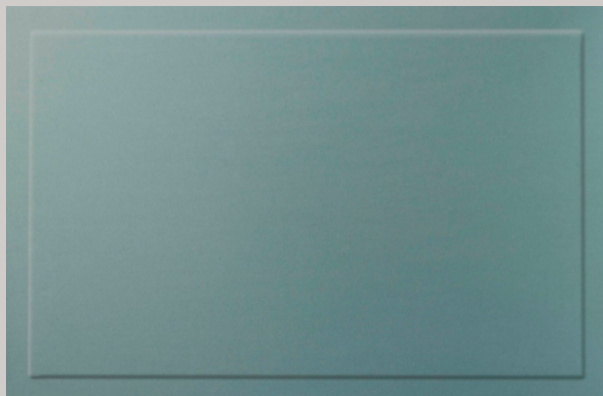

Dimensions:	625 mm x 410 mm x 66 mm
Material:	Gypsum plaster board
Frequency range:	120 Hz – 20000 Hz
Equalization:	LoftSonic DSP amplifier
Dispersion angle:	180° x 180°
Power handling*:	240 W / 4 Ω
Sensitivity:	90 dB (1 W / 1m)
Max. SPL:	110 dB (1 m)
Manufacturer:	Loftsonic GmbH & Co. KG
Model:	LoftSonic Phase-Line 240 DW CE

* Peak with HP 24 dB/oct 220 Hz

Phase-Line 240 DW CE

Invisible Mid-High Loudspeaker for horizontal installation in Drywall and Solid Construction



When installing in vertical surfaces, install crosswise

Dimensions drawing

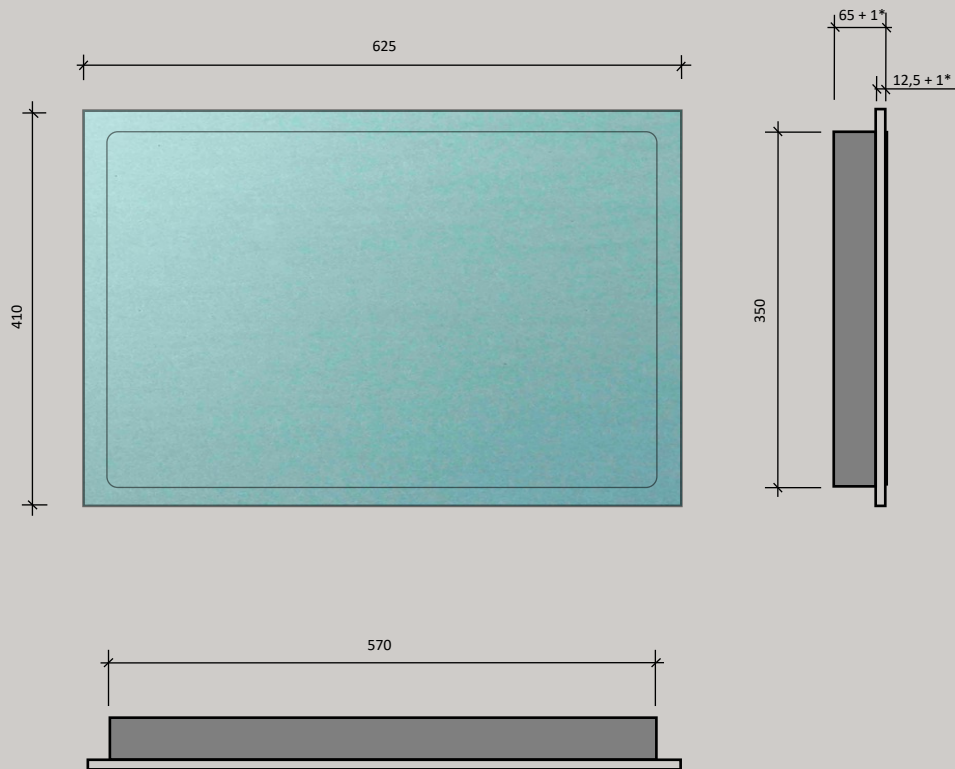

***Raised membrane**

Dimensions in mm

Phase-Line 240 DW LS

Invisible Mid-High Line Source Loudspeaker for Drywall and Solid Construction



When installing in vertical surfaces, install upright

Description / Technical data

Flat panel line source loudspeaker on the principle of the bending wave transducer with a flat panel membrane, which is brought to vibration by electrical exciters mounted to the back and due to a special construction, the principle-related diffuse radiation characteristic is converted into a direct sound radiation characteristic.

The loudspeaker comprises a conventional gypsum plaster board with a factory-integrated flat panel loudspeaker.

The 12.5 mm plaster board is raised by ambossing the area of the membrane. This enables flush filling with joint tape to the surrounding planking without having to plaster the membrane. This guarantees absolute sound neutrality after installation.

The surface can be coated with all conventional materials, such as, for example, paint, wallpapers, etc.



Dimensions:	450 mm x 1200 mm x 66 mm
Material:	Gypsum plaster board
Frequency range:	120 Hz – 20000 Hz
Equalization:	LoftSonic DSP amplifier
Dispersion angle:	180° x 180°
Power handling*:	240 W / 4 Ω
Sensitivity:	90 dB (1 W / 1m)
Max. SPL:	110 dB (1 m)
Manufacturer:	Loftsonic GmbH & Co. KG
Model:	LoftSonic Phase-Line 240 DW LS

* Peak with HP 24 dB/oct 220 Hz

Phase-Line 240 DW LS

Invisible Mid-High Line Source Loudspeaker
for Drywall and Solid Construction



When installing in vertical surfaces, install upright

Dimensions drawing



*Raised membrane

Dimensions in mm

Phase-Line 400 DW LS

Invisible Mid-High Line Source Loudspeaker for Drywall and Solid Construction



Description / Technical data

Flat panel line source loudspeaker on the principle of the bending wave transducer with a flat panel membrane, which is brought to vibration by electrical exciters mounted to the back and due to a special construction, the principle-related diffuse radiation characteristic is converted into a direct sound radiation characteristic.

The loudspeaker comprises a conventional gypsum plaster board with a factory-integrated flat panel loudspeaker.

The 12.5 mm plaster board is raised by ambossing the area of the membrane. This enables flush filling with joint tape to the surrounding planking without having to plaster the membrane. This guarantees absolute sound neutrality after installation.

The surface can be coated with all conventional materials, such as, for example, paint, wallpapers, etc.

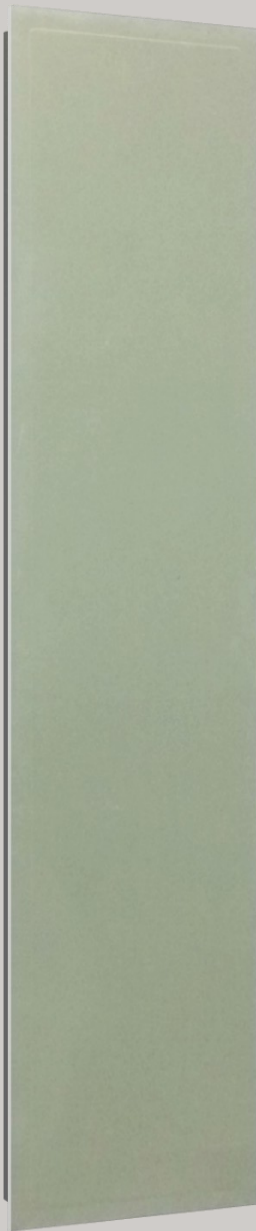

Dimensions:	450 mm x 1835 mm x 66 mm
Material:	Gypsum plaster board
Frequency range:	120 Hz – 20000 Hz
Equalization:	LoftSonic DSP amplifier
Dispersion angle:	180° x 180°
Power handling*:	400 W / 4,8 Ω
Sensitivity:	90 dB (1 W / 1m)
Max. SPL:	112 dB (1 m)
Manufacturer:	Loftsonic GmbH & Co. KG
Model:	LoftSonic Phase-Line 400 DW LS

* Peak with HP 24 dB/oct 220 Hz

Phase-Line 400 DW LS

Invisible Mid-High Line Source Loudspeaker
for Drywall and Solid Construction



When installing in vertical surfaces, install upright

Dimensions drawing



*Raised membrane
Dimensions in mm

Phase-Line 700 DW LS

Invisible Mid-High Line Source Loudspeaker for Drywall and Solid Construction



When installing in vertical surfaces, install upright

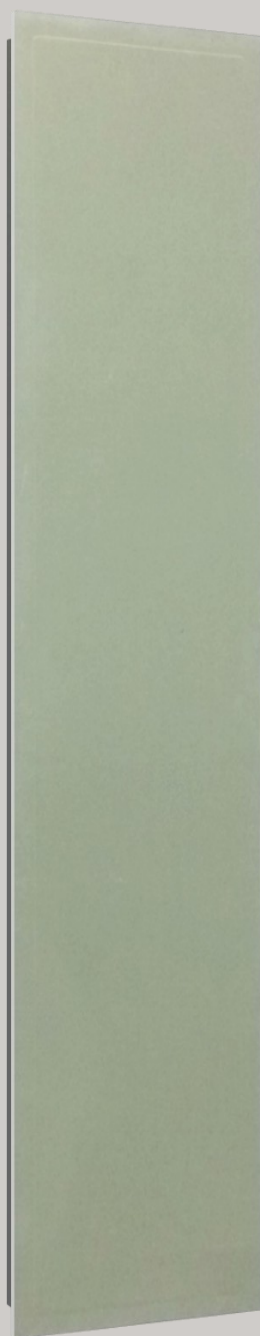

Description / Technical data

Flat panel line source loudspeaker on the principle of the bending wave transducer with a flat panel membrane, which is brought to vibration by electrical exciters mounted to the back and due to a special construction, the principle-related diffuse radiation characteristic is converted into a direct sound radiation characteristic.

The loudspeaker comprises a conventional gypsum plaster board with a factory-integrated flat panel loudspeaker.

The 12.5 mm plaster board is raised by ambossing the area of the membrane. This enables flush filling with joint tape to the surrounding planking without having to plaster the membrane. This guarantees absolute sound neutrality after installation.

The surface can be coated with all conventional materials, such as, for example, paint, wallpapers, etc.

Dimensions:	450 mm x 1995 mm x 66 mm
Material:	Gypsum plaster board
Frequency range:	120 Hz – 20000 Hz
Equalization:	LoftSonic DSP amplifier
Dispersion angle:	180° x 180°
Power handling*:	700 W / 4 Ω
Sensitivity:	91 dB (1 W / 1m)
Max. SPL:	113 dB (1 m)
Manufacturer:	Loftsonic GmbH & Co. KG
Model:	LoftSonic Phase-Line 700 DW LS

* Peak with HP 24 dB/oct 220 Hz

Phase-Line 700 DW LS

Invisible Mid-High Line Source
Loudspeaker for Drywall and Solid
Construction



When installing in vertical surfaces, install upright

Dimensions drawing



*Raised membrane
Dimensions in mm

Phase-Line 120 CM

Invisible Integrable Mid-High Loudspeaker Module for Furniture and Interior Work



When installing in vertical surfaces, install upright

Description / Technical data

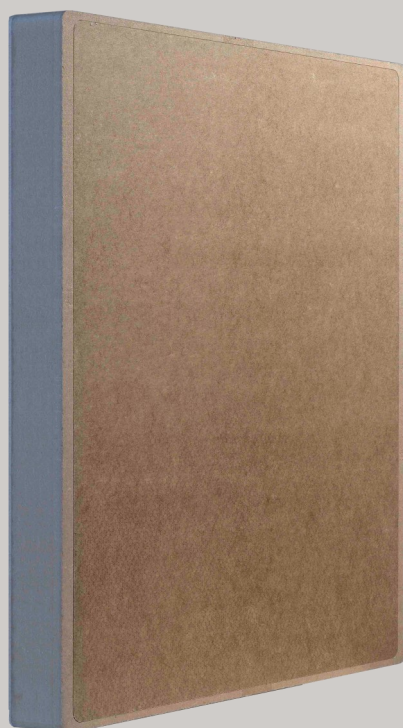

Flat panel loudspeaker for integration in wooden boards / furniture on the principle of the bending wave transducer with a flat panel membrane, which is brought to vibration by electrical exciters mounted to the back. and due to a special construction, the principle-related diffuse radiation characteristic is converted into a direct sound radiation characteristic.

The wooden board has to be milled down to a minimum thickness on the back in the area of the loudspeaker module and thus causes sound-neutrality.

The loudspeaker module has to be glued to the back of the thinned surface of the wooden board. This means the loudspeaker is jointlessly and invisibly integrated into the front of the wooden board. The milling work and the integration of the loudspeaker module into the wooden board / furniture can be done by Loftsonic or by the carpenter / contractor.

Materials

Suitable for all common wood-based panels like chipboards, MDF boards, solid wood boards, etc.

Possible surface coatings

All common surfaces and designs such as lacquers, veneers, laminates, etc.

Other materials on request, e.g. thin stone, glass, plexiglass, etc.

Dimensions:	435 mm x 570 mm x 64 mm
Frequency range:	120 Hz – 20000 Hz
Equalization:	LoftSonic DSP amplifier
Dispersion angle:	180° x 180°
Power handling*:	120 W / 8 Ω
Sensitivity:	88 dB (1 W / 1 m)
Max. SPL:	106 dB (1 m)

Manufacturer:	Loftsonic GmbH & Co. KG
Model:	LoftSonic PHASELINE 120 CM

* Peak with HP 24 dB/oct 220 Hz

Phase-Line 120 CM

Invisible Integrable Mid-High Loudspeaker
Module for Furniture and Interior Work



When installing in vertical surfaces, install upright

Dimensions drawing

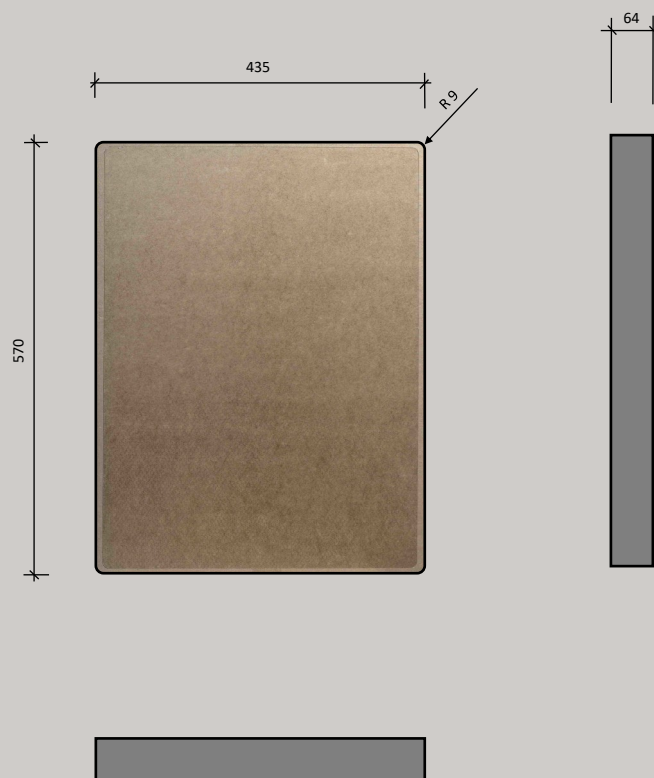

Dimensions in mm

Phase-Line 120 CM LB

Invisible horizontally Integrable Mid-High Loudspeaker Module for Furniture and Interior Work



When installing in vertical surfaces, install crosswise

Description / Technical data

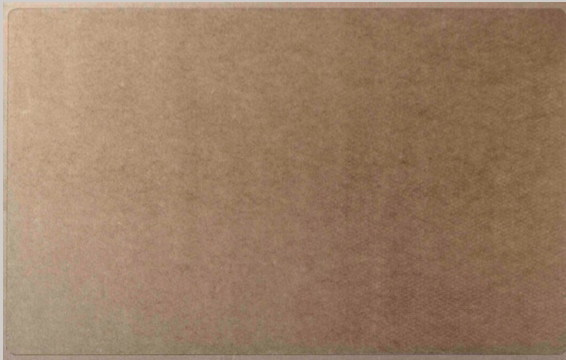

Flat panel line source loudspeaker for integration in wooden boards / furniture on the principle of the bending wave transducer with a flat panel membrane, which is brought to vibration by electrical exciters mounted to the back and due to a special construction, the principle-related diffuse radiation characteristic is converted into a direct sound radiation characteristic.

The wooden board has to be milled down to a minimum thickness on the back in the area of the loudspeaker module and thus causes sound-neutrality.

The loudspeaker module has to be glued to the back of the thinned surface of the wooden board. This means the loudspeaker is jointlessly and invisibly integrated into the front of the wooden board. The milling work and the integration of the loudspeaker module into the wooden board / furniture can be done by Loftsonic or by the carpenter / contractor.

Materials

Suitable for all common wood-based panels like chipboards, MDF boards, solid wood boards, etc.

Possible surface coatings

All common surfaces and designs such as lacquers, veneers, laminates, etc.

Other materials on request, e.g. thin stone, glass, plexiglass, etc.

Dimensions:	570 mm x 350 mm x 64 mm
Frequency range:	120 Hz – 20000 Hz
Equalization:	LoftSonic DSP amplifier
Dispersion angle:	180° x 180°
Power handling*:	120 W / 8 Ω
Sensitivity:	88 dB (1 W / 1m)
Max. SPL:	106 dB (1 m)
Manufacturer:	Loftsonic GmbH & Co. KG
Model:	LoftSonic PHASELINE 120 CM LB

* Peak with HP 24 dB/oct 220 Hz

Phase-Line 120 CM LB

Invisible horizontally Integrable Mid-High Loudspeaker Module for Furniture and Interior Work



When installing in vertical surfaces, install crosswise

Dimensions drawing

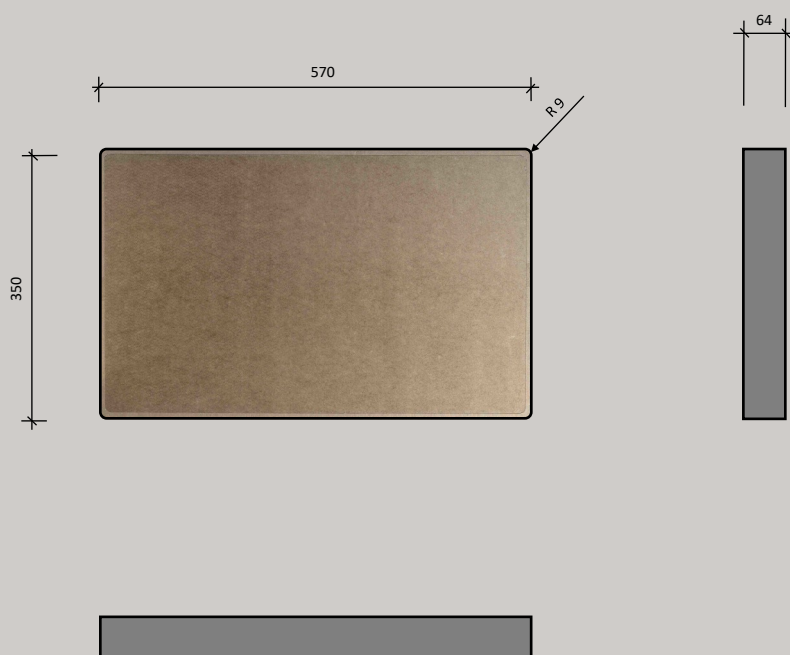

Dimensions in mm

Phase-Line 240 CM LB

Invisible horizontally Integrable Mid-High Loudspeaker Module for Furniture and Interior Work



When installing in vertical surfaces, install crosswise

Description / Technical data

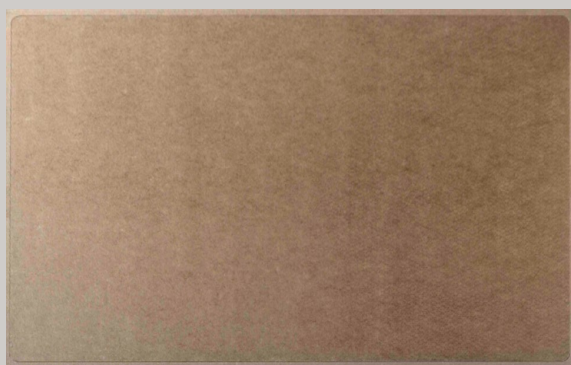

Flat panel line source loudspeaker for integration in wooden boards / furniture on the principle of the bending wave transducer with a flat panel membrane, which is brought to vibration by electrical exciters mounted to the back and due to a special construction, the principle-related diffuse radiation characteristic is converted into a direct sound radiation characteristic.

The wooden board has to be milled down to a minimum thickness on the back in the area of the loudspeaker module and thus causes sound-neutrality.

The loudspeaker module has to be glued to the back of the thinned surface of the wooden board. This means the loudspeaker is jointlessly and invisibly integrated into the front of the wooden board. The milling work and the integration of the loudspeaker module into the wooden board / furniture can be done by Loftsonic or by the carpenter / contractor.

Materials

Suitable for all common wood-based panels like chipboards, MDF boards, solid wood boards, etc.

Possible surface coatings

All common surfaces and designs such as lacquers, veneers, laminates, etc.

Other materials on request, e.g. thin stone, glass, plexiglass, etc.

Dimensions:	570 mm x 350 mm x 64 mm
Frequency range:	120 Hz – 20000 Hz
Equalization:	LoftSonic DSP amplifier
Dispersion angle:	180° x 180°
Power handling*:	240 W / 4 Ω
Sensitivity:	90 dB (1 W / 1m)
Max. SPL:	110 dB (1 m)
Manufacturer:	Loftsonic GmbH & Co. KG
Model:	LoftSonic PHASELINE 240 CM LB

* Peak with HP 24 dB/oct 220 Hz

Phase-Line 240 CM LB

Invisible horizontally Integrable Mid-High Loudspeaker Module for Furniture and Interior Work



When installing in vertical surfaces, install crosswise

Dimensions drawing

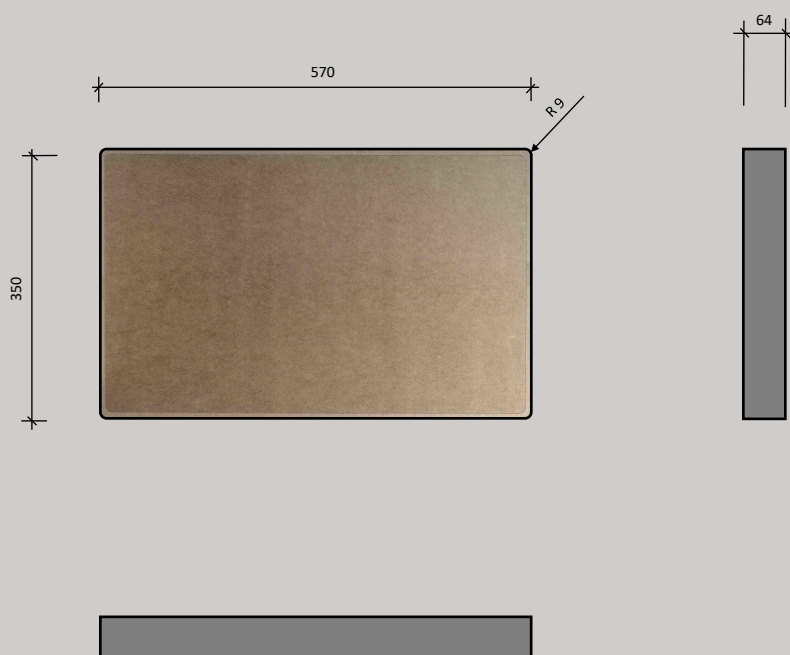

Dimensions in mm

Phase-Line 240 CM LS

Invisible Integrable Mid-High Line Source Loudspeaker Module for Furniture and Interior Work



When installing in vertical surfaces, install upright



Description / Technical data

Flat panel line source loudspeaker for integration in wooden boards / furniture on the principle of the bending wave transducer with a flat panel membrane, which is brought to vibration by electrical exciters mounted to the back and due to a special construction, the principle-related diffuse radiation characteristic is converted into a direct sound radiation characteristic.

The wooden board has to be milled down to a minimum thickness on the back in the area of the loudspeaker module and thus causes sound-neutrality.

The loudspeaker module has to be glued to the back of the thinned surface of the wooden board. This means the loudspeaker is jointlessly and invisibly integrated into the front of the wooden board. The milling work and the integration of the loudspeaker module into the wooden board / furniture can be done by Loftsonic or by the carpenter / contractor.

Materials

Suitable for all common wood-based panels like chipboards, MDF boards, solid wood boards, etc.

Possible surface coatings

All common surfaces and designs such as lacquers, veneers, laminates, etc.

Other materials on request, e.g. thin stone, glass, plexiglass, etc.

Dimensions:	395 mm x 1140 mm x 64 mm
Frequency range:	120 Hz – 20000 Hz
Equalization:	LoftSonic DSP amplifier
Dispersion angle:	180° x 180°
Power handling*:	240 W / 4 Ω
Sensitivity:	90 dB (1 W / 1 m)
Max. SPL:	110 dB (1 m)
Manufacturer:	Loftsonic GmbH & Co. KG
Model:	LoftSonic PHASELINE 240 CM LS

* Peak with HP 24 dB/oct 220 Hz

Phase-Line 240 CM LS

Invisible Integrable Mid-High Line Source
Loudspeaker Module for Furniture and
Interior Work



When installing in vertical surfaces, install upright

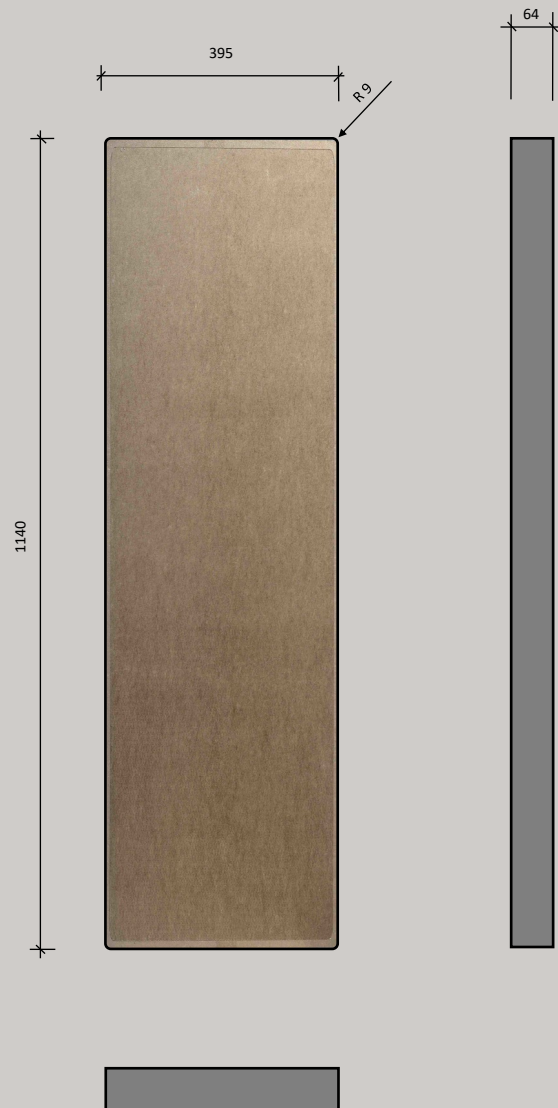

Dimensions in mm

Phase-Line 400 CM LS

Invisible Integrable Mid-High Line Source Loudspeaker Module for Furniture and Interior Work



When installing in vertical surfaces, install upright

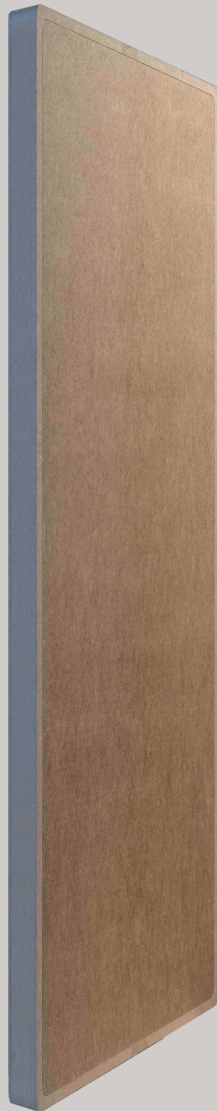

Description / Technical data

Flat panel line source loudspeaker for integration in wooden boards / furniture on the principle of the bending wave transducer with a flat panel membrane, which is brought to vibration by electrical exciters mounted to the back and due to a special construction, the principle-related diffuse radiation characteristic is converted into a direct sound radiation characteristic.

The wooden board has to be milled down to a minimum thickness on the back in the area of the loudspeaker module and thus causes sound-neutrality.

The loudspeaker module has to be glued to the back of the thinned surface of the wooden board. This means the loudspeaker is jointlessly and invisibly integrated into the front of the wooden board. The milling work and the integration of the loudspeaker module into the wooden board / furniture can be done by Loftsonic or by the carpenter / contractor.

Materials

Suitable for all common wood-based panels like chipboards, MDF boards, solid wood boards, etc.

Possible surface coatings

All common surfaces and designs such as lacquers, veneers, laminates, etc.

Other materials on request, e.g. thin stone, glass,

plexiglass, etc.

Dimensions:	395 mm x 1775 mm x 64 mm
Frequency range:	120 Hz – 20000 Hz
Equalization:	LoftSonic DSP amplifier
Dispersion angle:	180° x 180°
Power handling*:	400 W / 4,8 Ω
Sensitivity:	90 dB (1 W / 1m)
Max. SPL:	112 dB (1 m)
Manufacturer:	Loftsonic GmbH & Co. KG
Model:	LoftSonic PHASELINE 400 CM LS

* Peak with HP 24 dB/oct 220 Hz

Phase-Line 400 CM LS

Invisible Integrable Mid-High Line Source
Loudspeaker Module for Furniture and
Interior Work



When installing in vertical surfaces, install upright

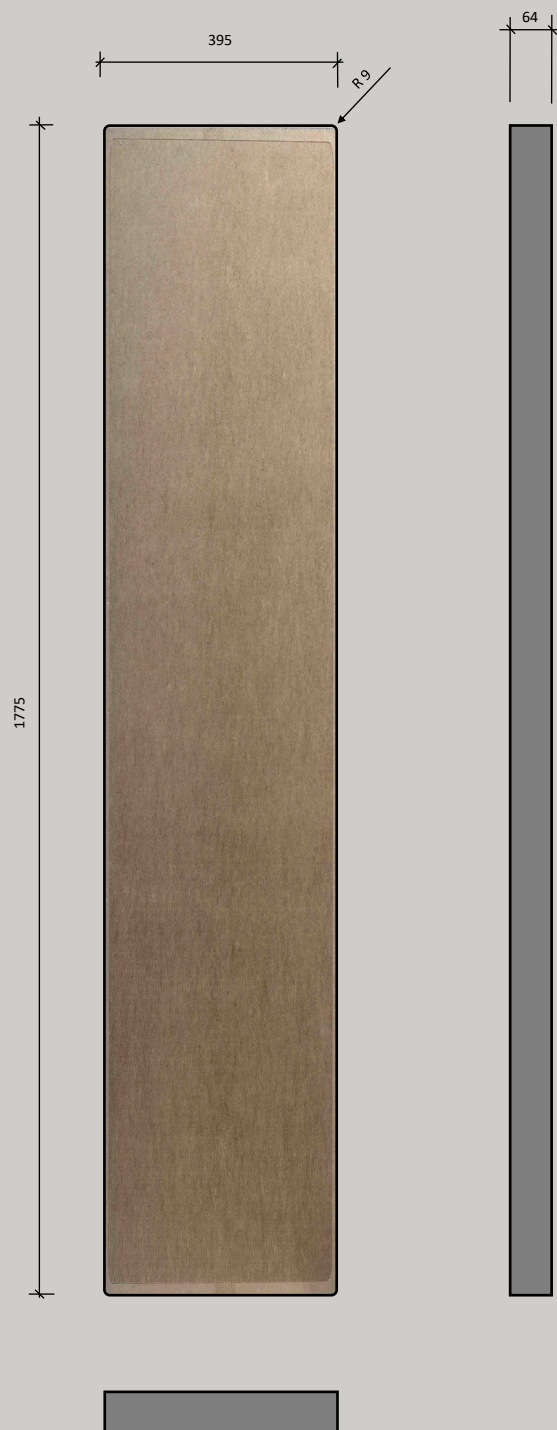

Dimensions in mm

Phase-Line 700 CM LS

Invisible Integrable Mid-High Line Source Loudspeaker Module for Furniture and Interior Work



When installing in vertical surfaces, install upright

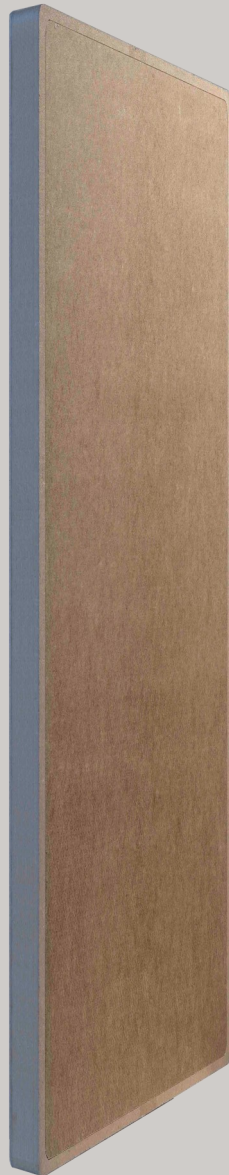

Description / Technical data

Flat panel line source loudspeaker for integration in wooden boards / furniture on the principle of the bending wave transducer with a flat panel membrane, which is brought to vibration by electrical exciters mounted to the back and due to a special construction, the principle-related diffuse radiation characteristic is converted into a direct sound radiation characteristic.

The wooden board has to be milled down to a minimum thickness on the back in the area of the loudspeaker module and thus causes sound-neutrality.

The loudspeaker module has to be glued to the back of the thinned surface of the wooden board. This means the loudspeaker is jointlessly and invisibly integrated into the front of the wooden board. The milling work and the integration of the loudspeaker module into the wooden board / furniture can be done by Loftsonic or by the carpenter / contractor.

Materials

Suitable for all common wood-based panels like chipboards, MDF boards, solid wood boards, etc.

Possible surface coatings

All common surfaces and designs such as lacquers, veneers, laminates, etc.

Other materials on request, e.g. thin stone, glass,

* Peak with HP 24 dB/oct 220 Hz

Dimensions:	395 mm x 1935 mm x 64 mm
Frequency range:	120 Hz – 20000 Hz
Equalization:	LoftSonic DSP amplifier
Dispersion angle:	180° x 180°
Power handling*:	700 W / 4 Ω
Sensitivity:	91 dB (1 W / 1 m)
Max. SPL:	113 dB (1 m)
Manufacturer:	Loftsonic GmbH & Co. KG
Model:	LoftSonic PHASELINE 700 CM LS

plexiglass, etc.

This brochure is intended to provide advice to the best of our knowledge. However, the content is not legally binding. We reserve the right to make technical changes at any time without prior notice.

Phase-Line 700 CM LS

Invisible Integrable Mid-High Line Source
Loudspeaker Module for Furniture and
Interior Work



When installing in vertical surfaces, install upright

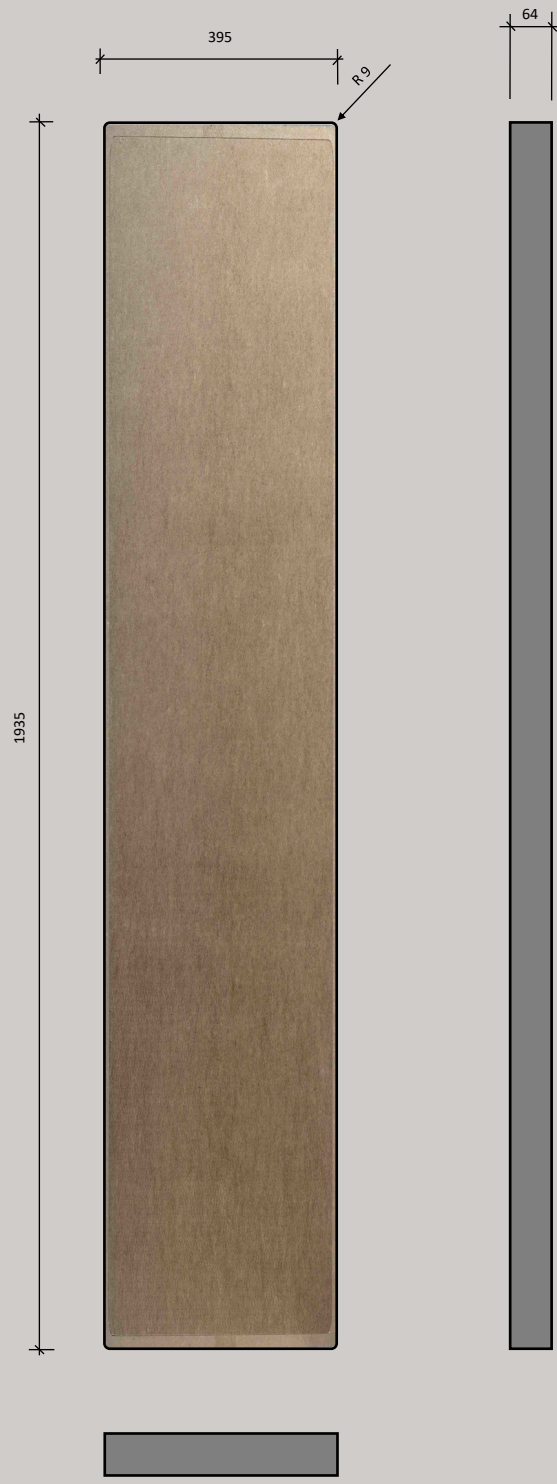

Phase-Line Concert 400 CS

Mid-high Line Source Loudspeaker



When installing in vertical surfaces, install upright

Description / Technical data

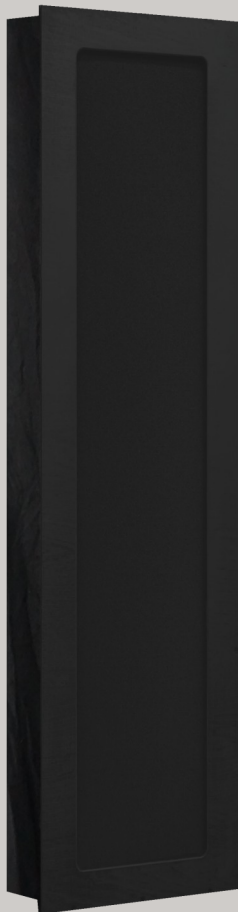

Flat panel line source loudspeaker on the principle of the bending wave transducer with a flat panel membrane, which is brought to vibration by electrical exciters mounted to the back. and due to a special construction, the principle-related diffuse radiation characteristic is converted into a direct sound radiation characteristic.

Dimensions:	305 mm x 1090 mm x 118 mm
Frequency range:	120 Hz – 20000 Hz
Equalization:	LoftSonic DSP amplifier
Dispersion angle:	180° x 180°
Power handling*:	400 W / 8 Ω
Sensitivity:	93 dB (1 W / 1 m)
Max. SPL:	115 dB (1 m)
Manufacturer:	Loftsonic GmbH & Co. KG
Model:	LoftSonic Concert 400 CS

* Peak with HP 24 dB/oct 220 Hz

Phase-Line Concert 400 CS

Mid-high Line Source Loudspeaker



When installing in vertical surfaces, install upright

Dimensions drawing

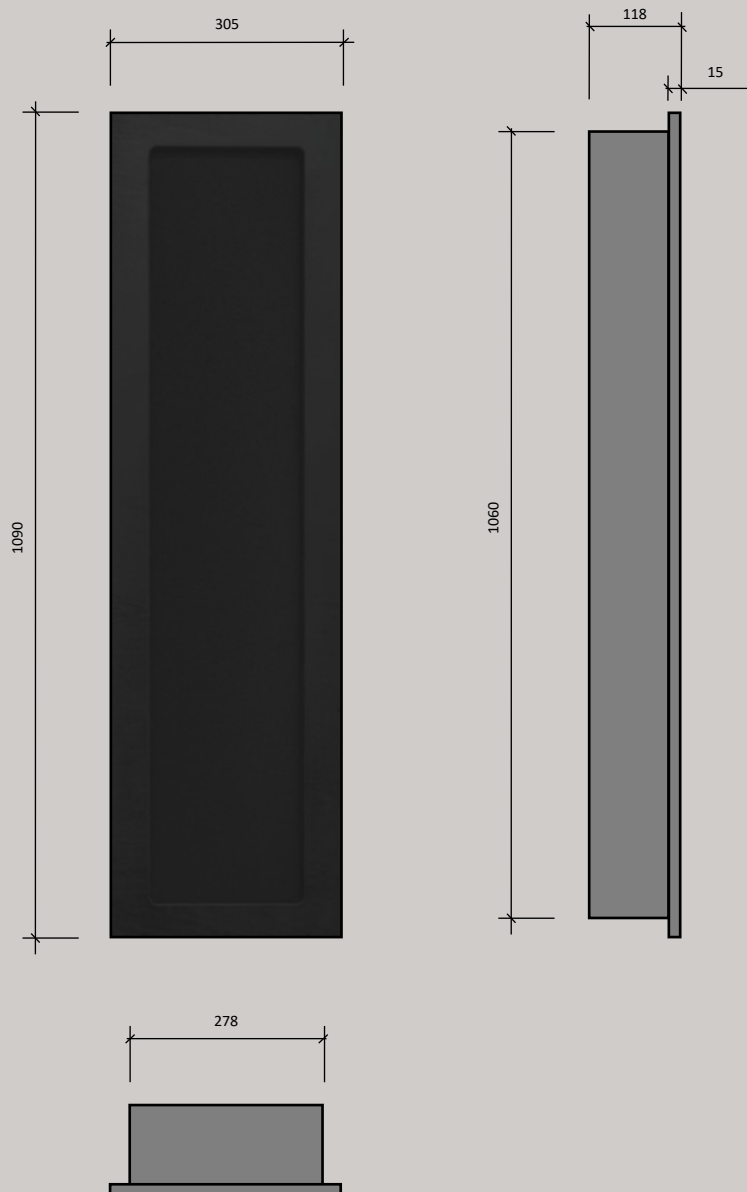

Dimensions in mm

Phase-Line Concert 700 CS

Mid-high Line Source Loudspeaker



When installing in vertical surfaces, install upright

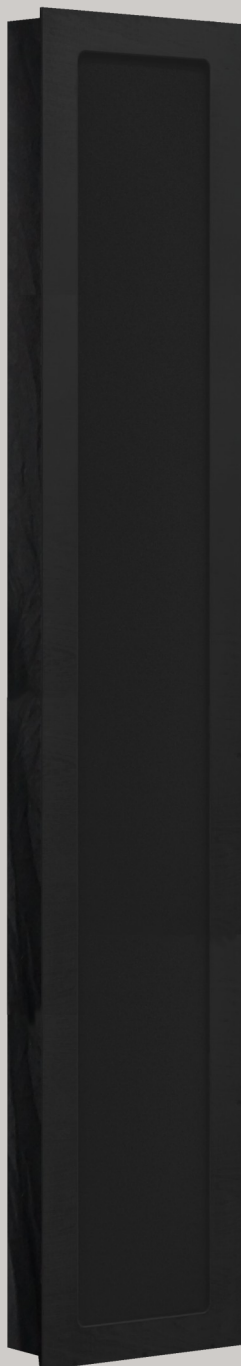

Description / Technical data

Flat panel line source loudspeaker on the principle of the bending wave transducer with a flat panel membrane, which is brought to vibration by electrical exciters mounted to the back and due to a special construction, the principle-related diffuse radiation characteristic is converted into a direct sound radiation characteristic.

Dimensions:	305 mm x 1700 mm x 118 mm
Frequency range:	120 Hz – 20000 Hz
Equalization:	LoftSonic DSP amplifier
Dispersion angle:	180° x 180°
Power handling*:	700 W / 4 Ω
Sensitivity:	94 dB (1 W / 1 m)
Max. SPL:	117 dB (1 m)
Manufacturer:	Loftsonic GmbH & Co. KG
Model:	LoftSonic Concert 700 CS

* Peak with HP 24 dB/oct 220 Hz

Phase-Line Concert 700 CS

Mid-high Line Source Loudspeaker



When installing in vertical surfaces, install upright

Dimensions drawing



Sub 12 DW

Invisible integrable subwoofer for drywall construction



Description / Technical data

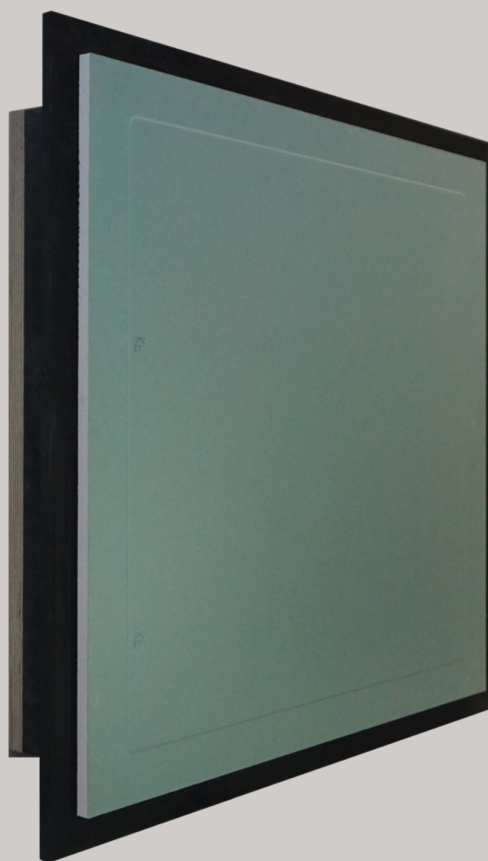

Subwoofer with a flat membrane which is brought to vibrate by a rear-positioned low frequency driver.

The loudspeaker comprises a conventional gypsum plaster board with a factory-integrated flat-panel loudspeaker membrane.

The 12.5 mm plaster board is raised by ambossing the area of the membrane. This enables flush filling with joint tape to the surrounding planking without having to plaster the membrane. This guarantees absolute sound neutrality after installation.

The surface can be coated with conventional materials, such as, for example, paint and wallpapers.

Dimensions:	685 mm x 685 mm x 135 mm
Material:	Gypsum plaster board
Frequency range:	30 Hz – 250 Hz
Equalization:	LoftSonic DSP amplifier
Power handling:	250 W / 8 Ω
Sensitivity:	85 dB (1 W / 1 m)
Max. SPL:	108 dB (1 m)

Manufacturer:	Loftsonic GmbH & Co. KG
Model:	Sub-Line 12 DW

Sub 12 DW

Invisible Flat Panel Subwoofer for Drywall Construction



Dimensions drawing

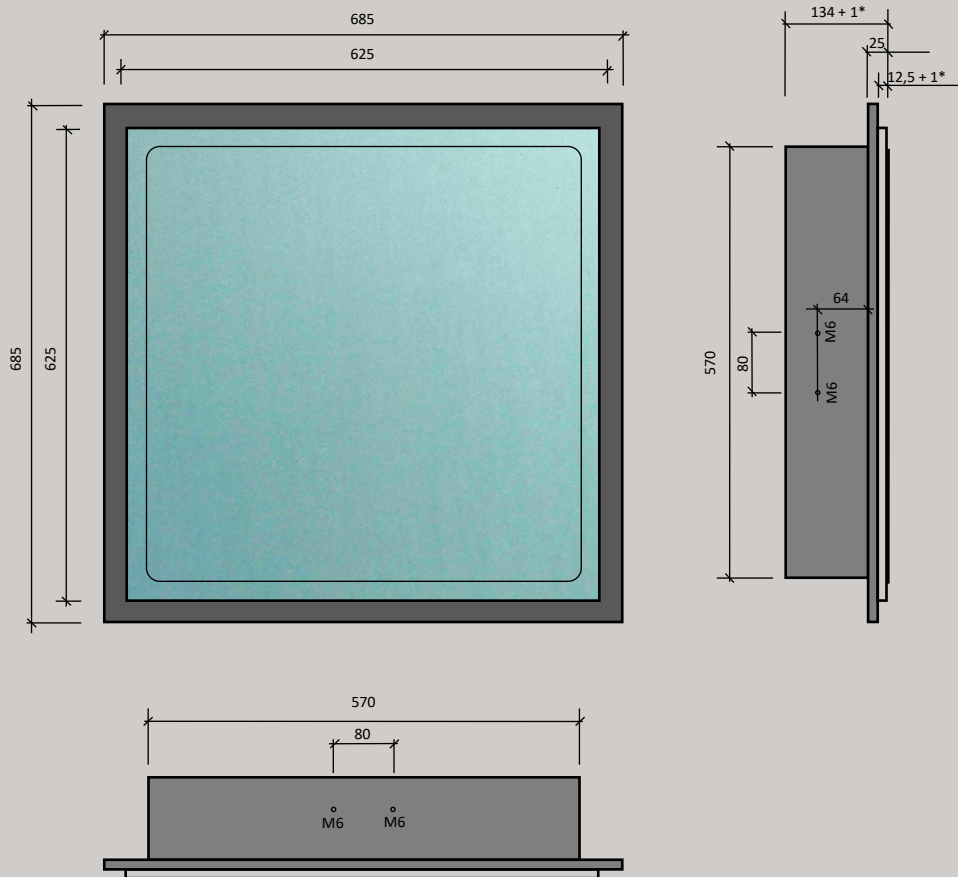

*Protruding membrane

Dimensions in mm

Sub 12 FF

12" Frontfire Subwoofer



Description / Technical data



12" frontfire subwoofer in a flat design.

Dimensions:	440 mm x 410 mm x 135 mm
Frequency range:	30 Hz – 250 Hz
Equalization:	LoftSonic DSP amplifier
Power handling:	250 W / 8 Ω
Sensitivity:	85 dB (1 W / 1 m)
Max. SPL:	108 dB (1 m)

Manufacturer:	Loftsonic GmbH & Co. KG
Model:	Sub 12 FF

Sub 12 FF

12" Frontfire Subwoofer



Dimensions drawing

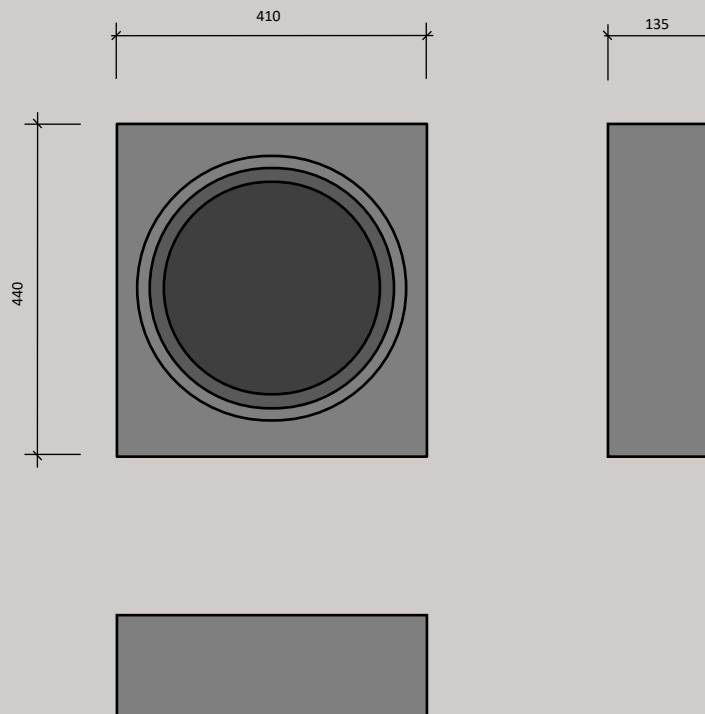

Dimensions in mm

Sub 12 SF

12" Slotfire Subwoofer



Description / Technical data



12" slotfire subwoofer in a flat design for installation in hollow spaces.

Dimensions:	430 mm x 570 mm x 198 mm
Frequency range:	30 Hz – 250 Hz
Equalization:	LoftSonic DSP amplifier
Power handling:	250 W / 8 Ω
Sensitivity:	85 dB (1 W / 1m)
Max. SPL:	108 dB (1 m)

Manufacturer:	Loftsonic GmbH & Co. KG
Model:	Sub 12 SF

Sub 12 SF

12" Slotfire Subwoofer



Dimensions drawing

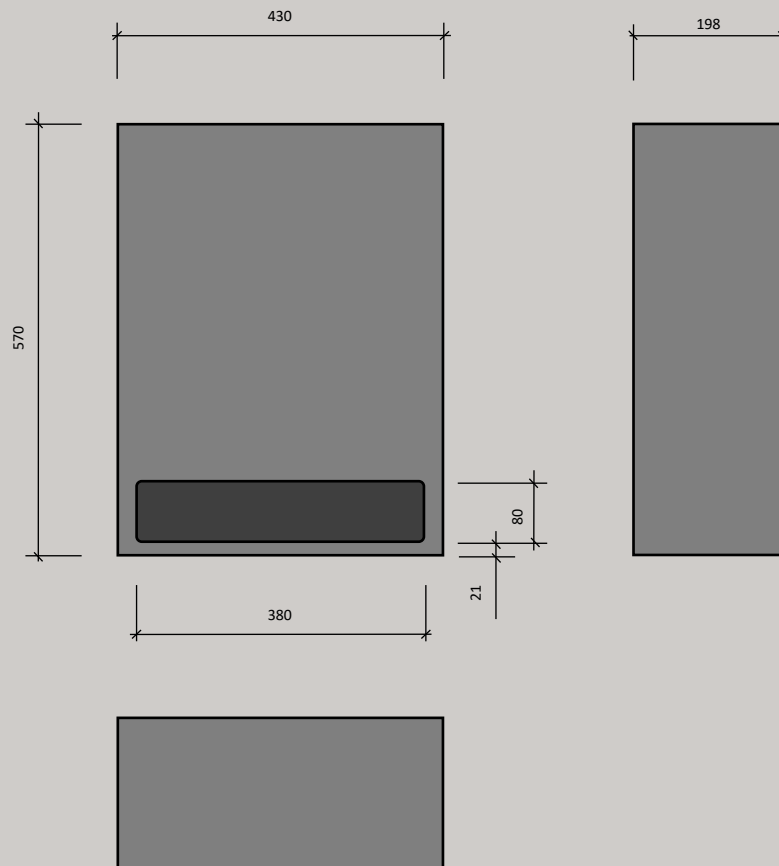

Dimensions in mm

Sub 12-2 SF

Double 12" Slotfire Subwoofer



Description / Technical data



Double 12" slotfire subwoofer in a flat design for installation in hollow spaces.

Dimensions:	820 mm x 570 mm x 198 mm
Frequency range:	30 Hz – 250 Hz
Equalization:	LoftSonic DSP amplifier
Power handling:	500 W / 4 Ω
Sensitivity:	88 dB (1 W / 1m)
Max. SPL:	114 dB (1 m)

Manufacturer:	Loftsonic GmbH & Co. KG
Model:	Sub 12-2 SF

Sub 12-2 SF

Double 12" Slotfire Subwoofer



Dimensions drawing

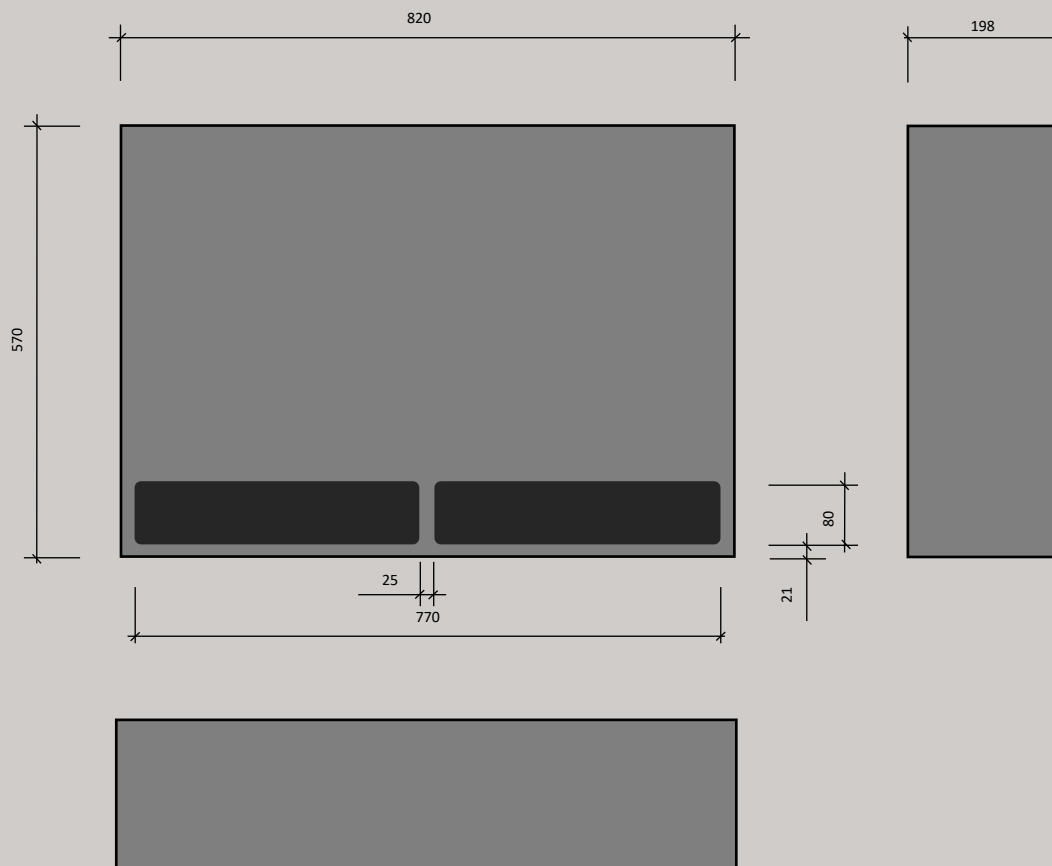

Dimensions in mm

Sub 12-2 Boxer DF

Double 12" Downfire Subwoofer



Description / Technical data

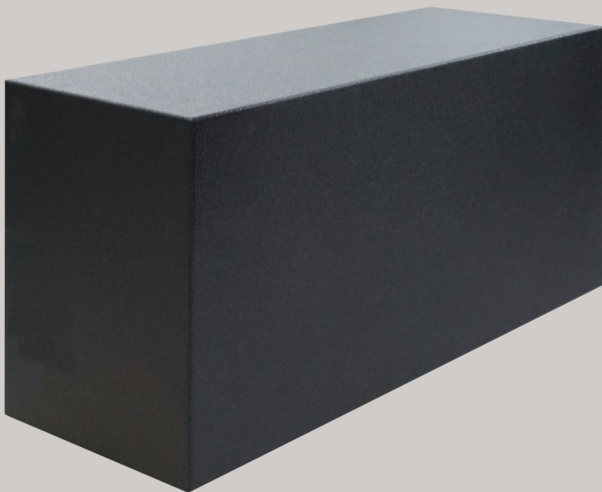

Double 12" slotfire subwoofer with opposing low-vibration speaker arrangement for installation in lowboards

Dimensions:	650 mm x 360 mm x 360 mm
Frequency range:	30 Hz – 250 Hz
Equalization:	LoftSonic DSP amplifier
Power handling:	1600 W / 4 Ω
Sensitivity:	88 dB (1 W / 1m)
Max. SPL:	119 dB (1 m)

Manufacturer:	Loftsonic GmbH & Co. KG
Model:	Sub 12-2 Boxer DF

Sub 12-2 Boxer DF

Double 12" Downfire Subwoofer



Dimensions drawing

Bottom View

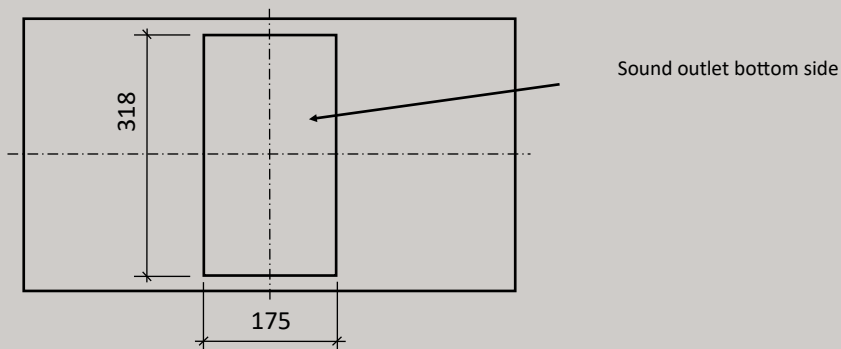

Front View

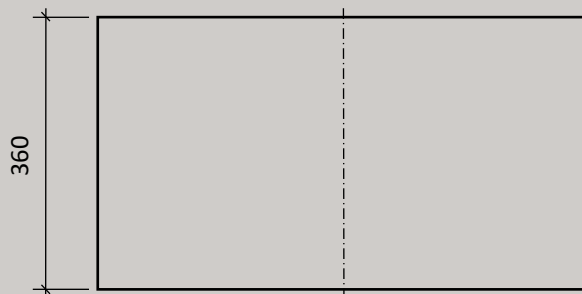

Side View

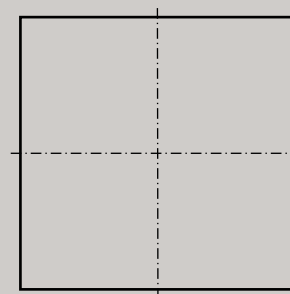

Top View

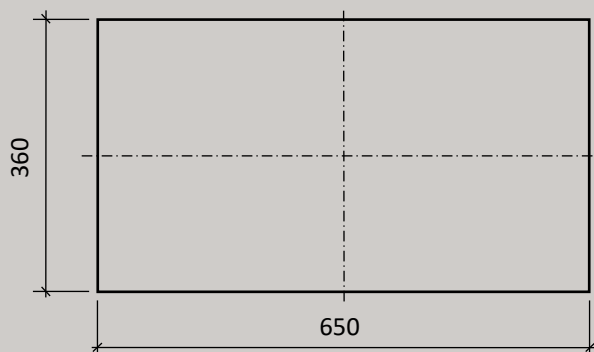

Dimensions in mm

Sub 12-2 Boxer DF Slot

Double 12" Downfire Subwoofer



Description / Technical data

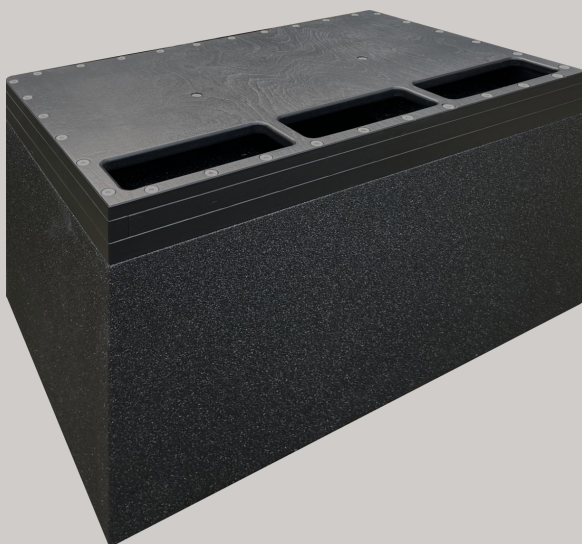
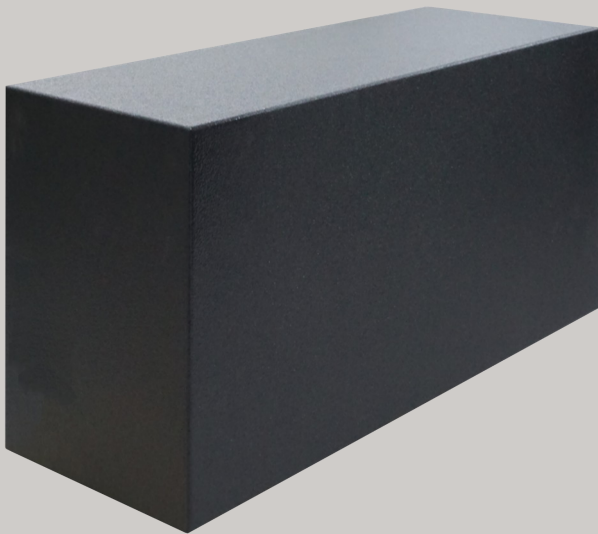

Double 12" slotfire subwoofer with opposing low-vibration speaker arrangement for installation in lowboards

Dimensions:	650 mm x 440 mm x 360 mm
Frequency range:	30 Hz – 250 Hz
Equalization:	LoftSonic DSP amplifier
Power handling:	1600 W / 4 Ω
Sensitivity:	92 dB (1 W / 1m)
Max. SPL:	123 dB (1 m)

Manufacturer:	Loftsonic GmbH & Co. KG
Model:	Sub 12-2 Boxer DF Slot

Sub 12-2 Boxer DF Slot

Double 12" Downfire Subwoofer



Bottom view

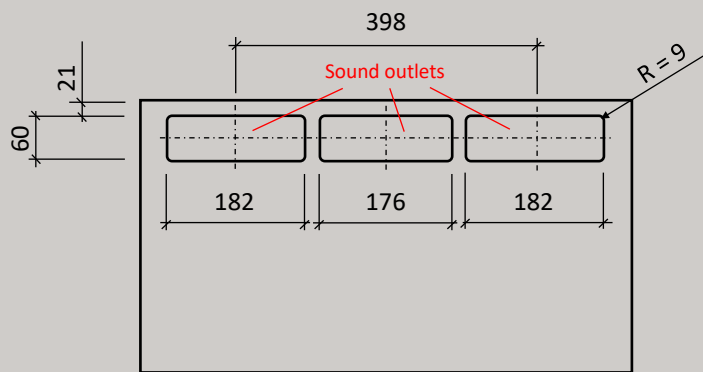

Dimensions drawing

Front View

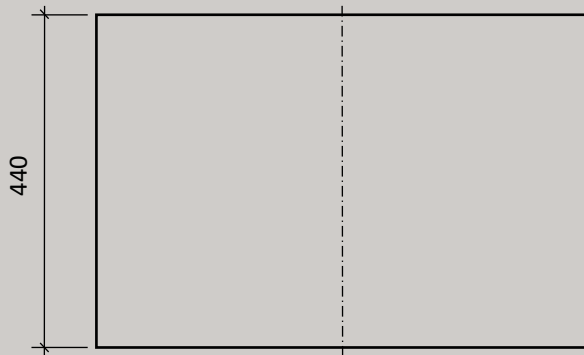

Side View



Top View



Dimensions in mm

Sub 302 DF

Double 12" Downfire Subwoofer



Description / Technical data

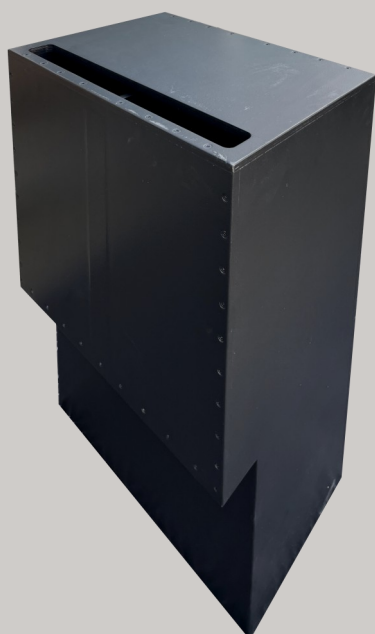

Double 12" slotfire subwoofer with opposing low-vibration speaker arrangement for installation in furniture

Dimensions:	800 mm x 430 mm x 302 mm
Frequency range:	30 Hz – 250 Hz
Equalization:	LoftSonic DSP amplifier
Power handling:	500 W / 4 Ω
Sensitivity:	88 dB (1 W / 1m)
Max. SPL:	115 dB (1 m)
Manufacturer:	Loftsonic GmbH & Co. KG
Model:	Sub 302 DF

Sub 302 DF

Double 12" Downfire Subwoofer



Dimensions drawing

Bottom view

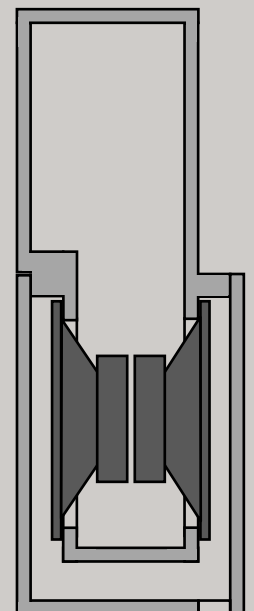
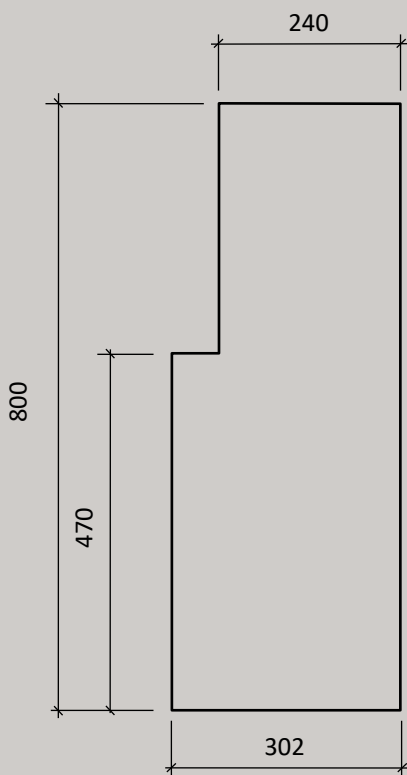
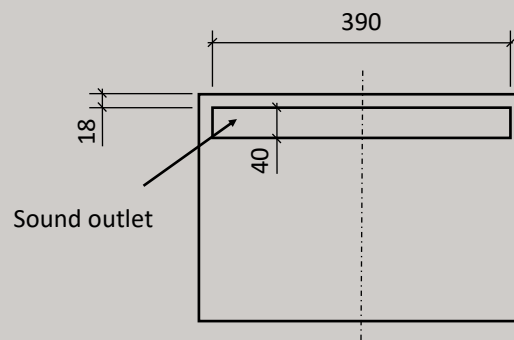

Dimensions in mm

Sub 15 FF

15" Frontfire Subwoofer



Description / Technical data



15" frontfire subwoofer.

Dimensions:	470 mm x 470 mm x 395 mm
Frequency range:	30 Hz – 250 Hz
Equalization:	LoftSonic DSP amplifier
Power handling:	1000 W / 8 Ω
Sensitivity:	95 dB (1 W / 1m)
Max. SPL:	122 dB (1 m)

Fabrikat:	Loftsonic GmbH & Co. KG
Typ:	Sub 15 FF

Sub 15 FF

15" Frontfire Subwoofer



Dimensions drawing

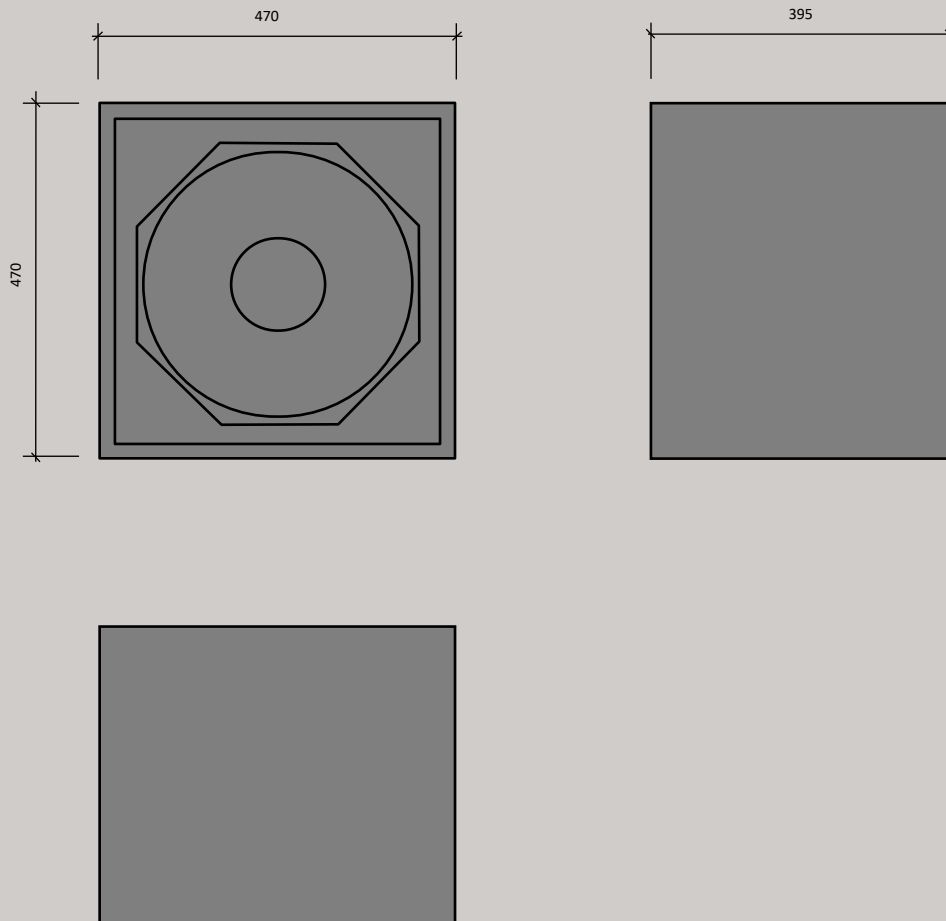

Dimensions in mm

Sub 15-2 FF

Double 15" Frontfire Subwoofer



Description / Technical data



Double 15" frontfire subwoofer.

Dimensions:	470 mm x 940 mm x 395 mm
Frequency range:	30 Hz – 250 Hz
Equalization:	LoftSonic DSP amplifier
Power handling:	2000 W / 4 Ω
Sensitivity:	98 dB (1 W / 1m)
Max. SPL:	128 dB (1 m)
Manufacturer:	Loftsonic GmbH & Co. KG
Model:	Sub 15-2 FF

Sub 15-2 FF

Double 15" Frontfire Subwoofer



Dimensions drawing

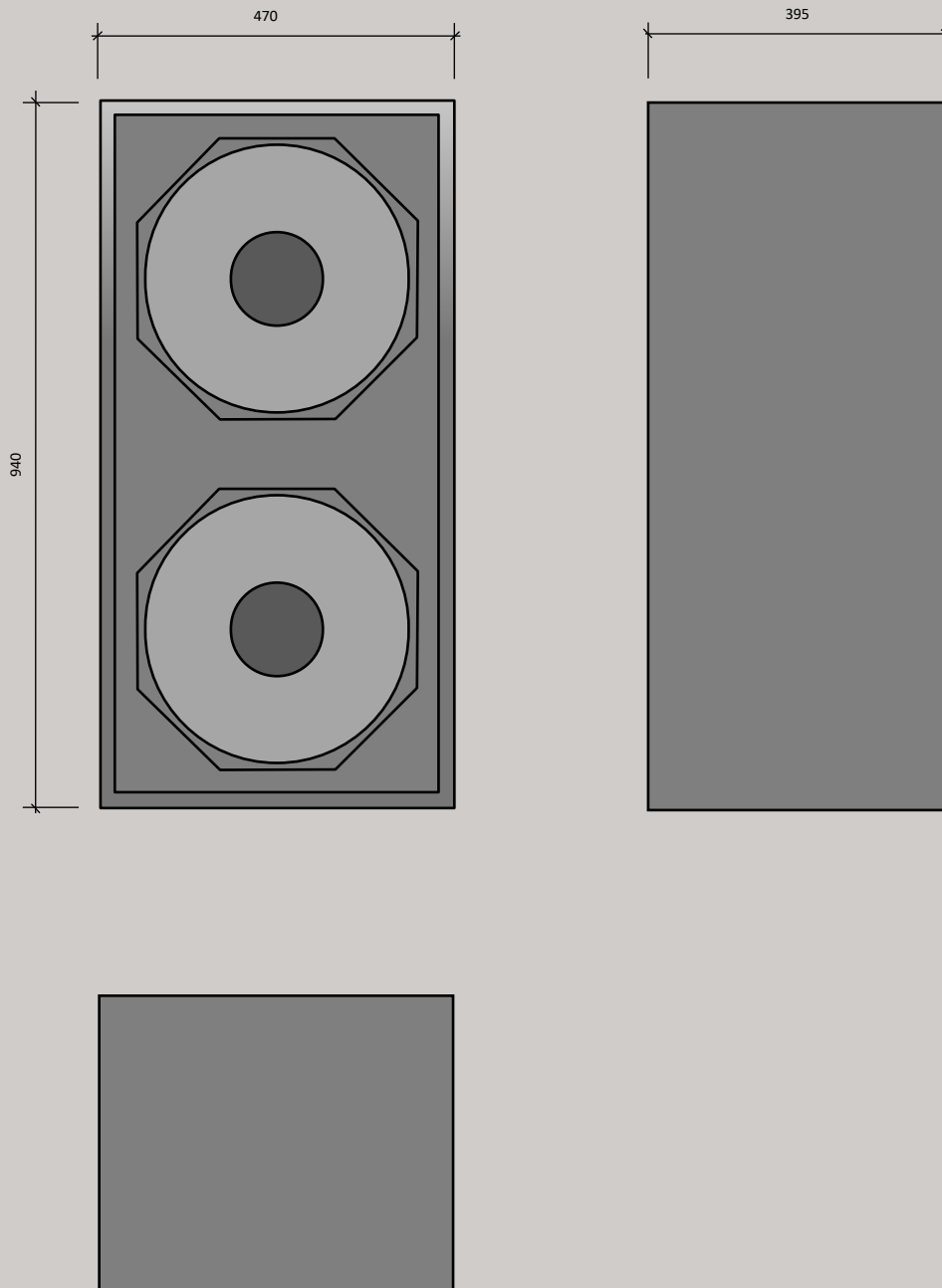

Dimensions in mm

Sub 15-2 Boxer DF

Double 15" Downfire Subwoofer



Description / Technical data

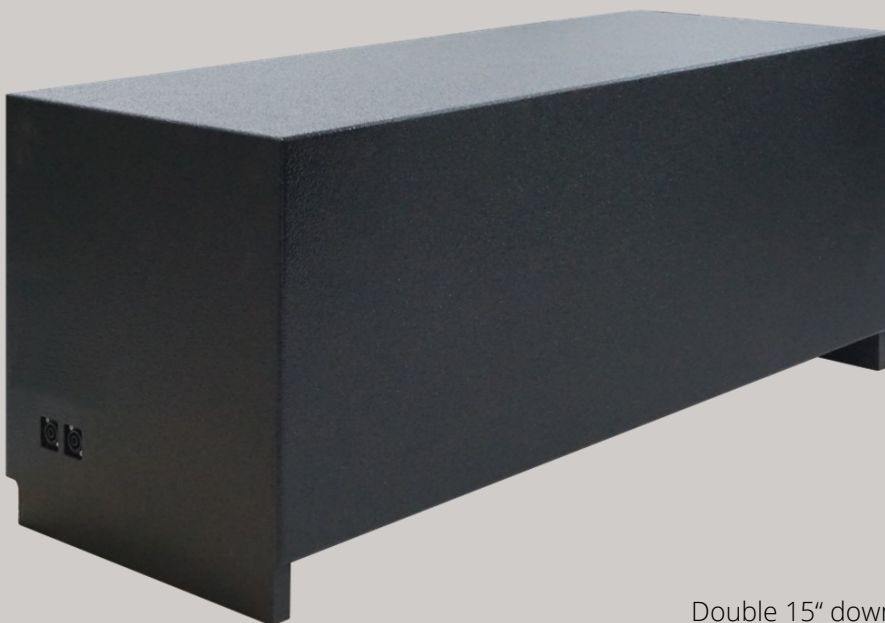

Double 15" downfire subwoofer according to the boxer principle.

Dimensions:	1060 mm x 510 mm x 440 mm
Frequency range:	30 Hz – 250 Hz
Equalization:	LoftSonic DSP amplifier
Power handling:	2000 W / 4 Ω
Sensitivity:	98 dB (1 W / 1m)
Max. SPL:	128 dB (1 m)

Manufacturer:	Loftsonic GmbH & Co. KG
Model:	Sub 15-2 Boxer DF

Sub 15-2 Boxer DF

Double 15" Downfire Subwoofer



Dimensions drawing

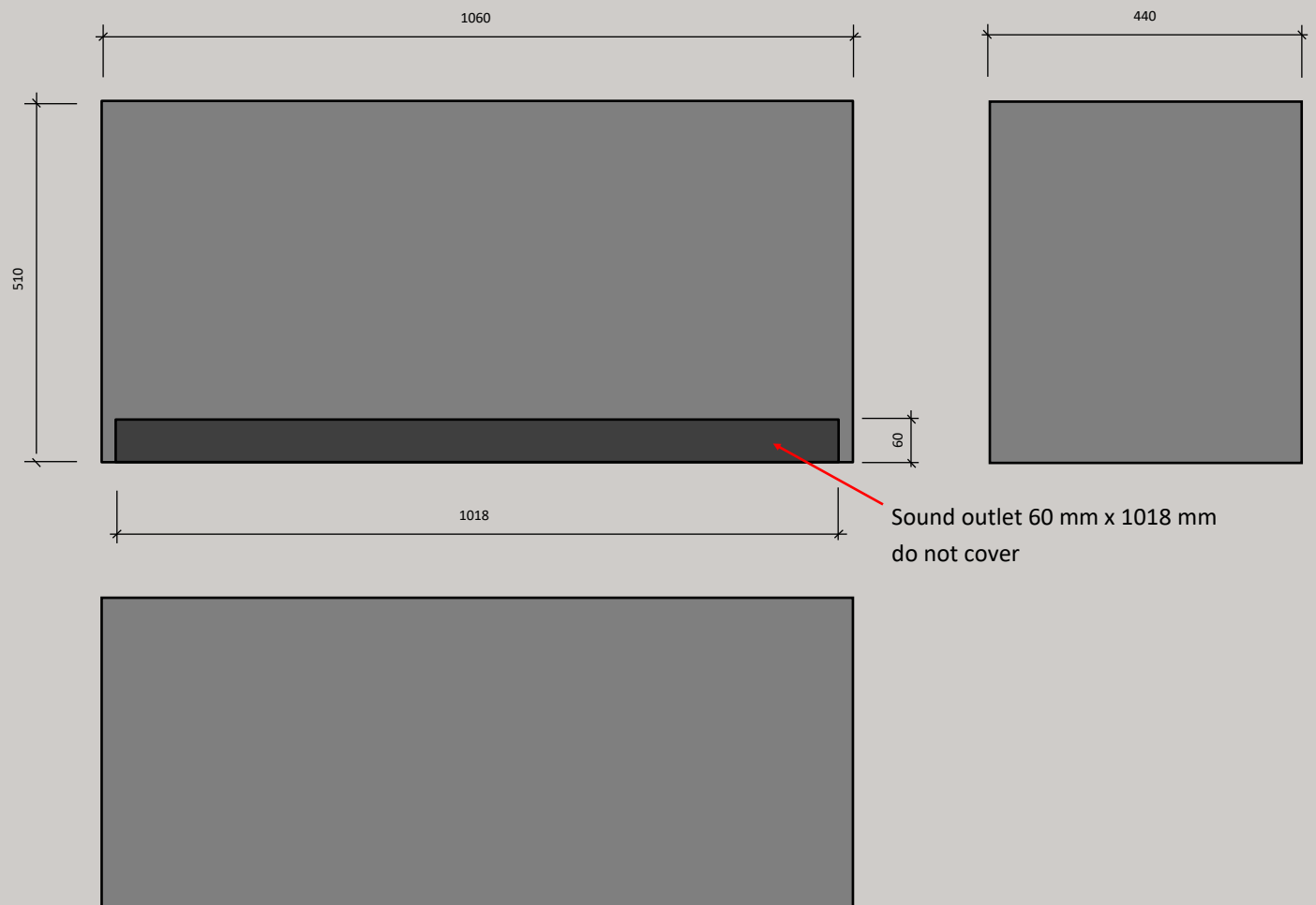

Dimensions in mm

Amp 19

19" DSP Amplifier



Description / Technical data



2 - 8 channel 19" DSP system amplifier 1000

Model	Power	Dimensions
Power-Rack 1000-2	2 x 500 watts 1 x 1000 watts bridged	19", 2 HE
Power-Rack 1000-4	4 x 500 watts 2 x 1000 watts bridged	19", 2 HE
Power-Rack 1000-6	6 x 500 watts 3 x 1000 watts bridged	19", 2 HE
Power-Rack 1000-8	8 x 500 watts 4 x 1000 watts bridged	19", 2 HE

2 - 8 channel 19" DSP system amplifier 1600

Model	Power	Dimensions
Power-Rack 1600-2	2 x 800 watts 1 x 1600 watts bridged	19", 2 HE
Power-Rack 1600-4	4 x 800 watts 2 x 1600 watts bridged	19", 2 HE
Power-Rack 1600-6	6 x 800 watts 3 x 1600 watts bridged	19", 2 HE
Power-Rack 1600-8	8 x 800 watts 4 x 1600 watts bridged	19", 2 HE

Amp 19

19" DSP Amplifier



Dimensions drawing

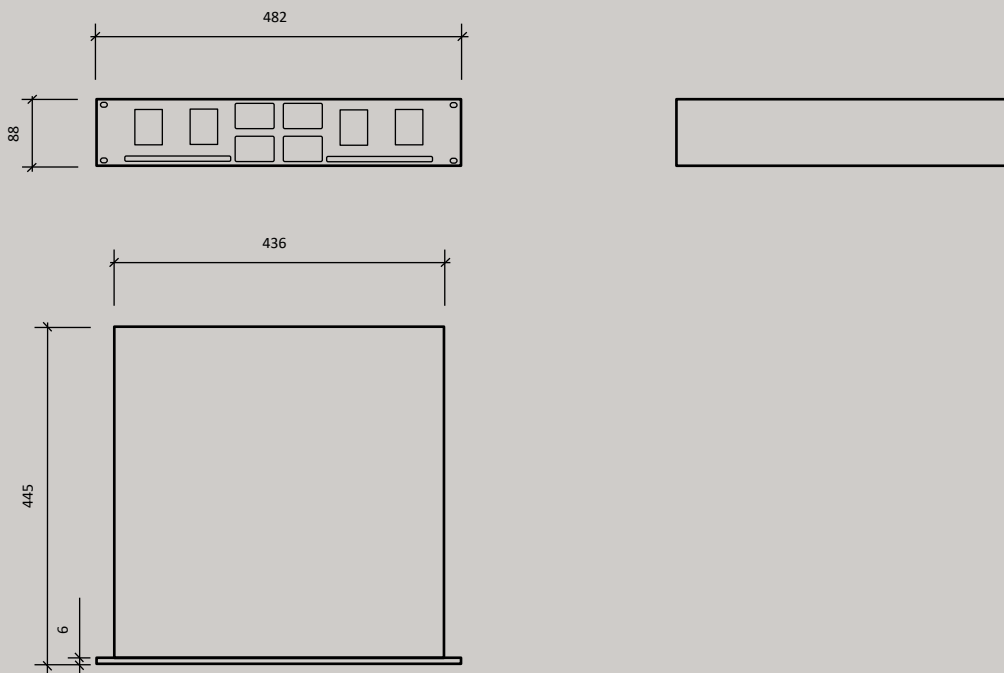

Dimensions in mm

Loftsonic GmbH & Co. KG

Am Hemel 2 A

D-55124 Mainz

GERMANY

Tel. +49 6 131 60 30 723

Fax +49 6 131 60 30 796

Email: info@LoftSonic.de

Data Specification Sheets - 2026/01/01